

| PARTS LIST | | | | |
|------------|-----|-------|-------------|------------------------------------|
| ITEM | QTY | ISSUE | PART NUMBER | DESCRIPTION |
| 1 | 1 | m | 152-03-1019 | body sub assy |
| 2 | 1 | h | 152-03-1022 | door sub assy |
| 3 | 1 | c | 152-02-1006 | base |
| 4 | 1 | c | 152-02-1005 | sill |
| 5 | 12 | | M8SLFHRN | M8 S/S Large Flange Hexsert |
| 6 | 4 | | 412SCPHM | M4 x 12 S/S CSK Pozi Machine Screw |
| 7 | 4 | | M4SN | M4 S/S Nut |

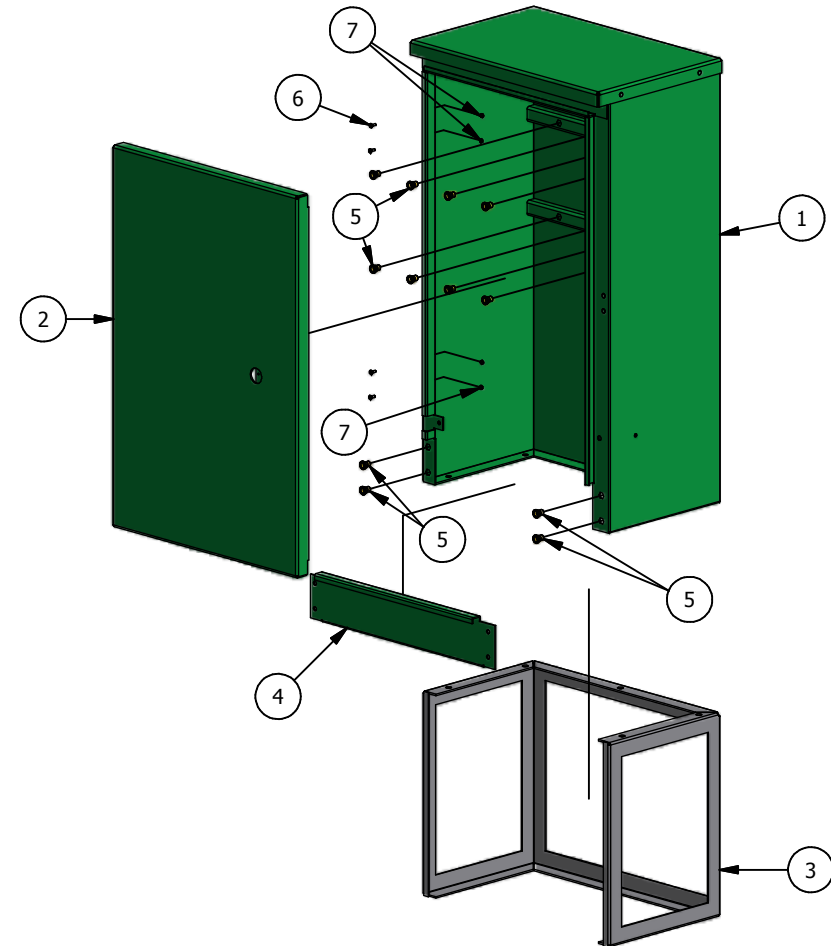

REVISION HISTORY

| REV | DESCRIPTION | DATE | APPROVED | ECN # |
|-----|------------------------------|------------|----------|-------|
| N | lintel rivets updated | 15/03/2013 | ND | 1240 |
| O | door updated to close up gap | 6/11/2013 | JW | 1351 |

| | | | | | | | |
|--|--|-------------|------------------|---|---------------------------------------|------------------------------------|--|
| | TOLERANCES: LINEAR: ±0.5 ANGULAR: ±0.5° | DRAWN: AJS | DATE: 24/09/2010 | CUSTOMER: RDL | TITLE: AL500x900x340 ~ final assembly | DRAWING NO. - REV. 152-04-1018 (o) | |
| | | CHECKED: ND | DATE: 24/11/2009 | CAD GENERATED DRAWING DO NOT MANUALLY UPDATE DO NOT SCALE DRAWING | | Customer reference ~ | |
| UNLESS OTHERWISE SPECIFIED: DIMENSIONS ARE IN MILLIMETERS | | | | WEIGHT: 20.20 kg | | MATERIAL: as per specifications | |
| | | | | | | FINISH: as per specifications | |
| | | | | | | SHEET OF SHEET: 1 / 1 | |