

PARTS LIST				
ITEM	QTY	ISSUE	PART NUMBER	DESCRIPTION
1	1	c	152-02-1017	Base
2	1	d	152-03-1110	Body Sub Assembly
3	4		M5SLFRN	M5 S/S Large Flange Rivnut
4	2		M8SLFHRN	M8 S/S Large Flange Hexsert
5	1	c	152-02-1014	Sill
6	1	d	152-03-1111	Door Sub Assembly
7	4		RIV532	OBS11-00516 5/32" Stavex Rivet S/S

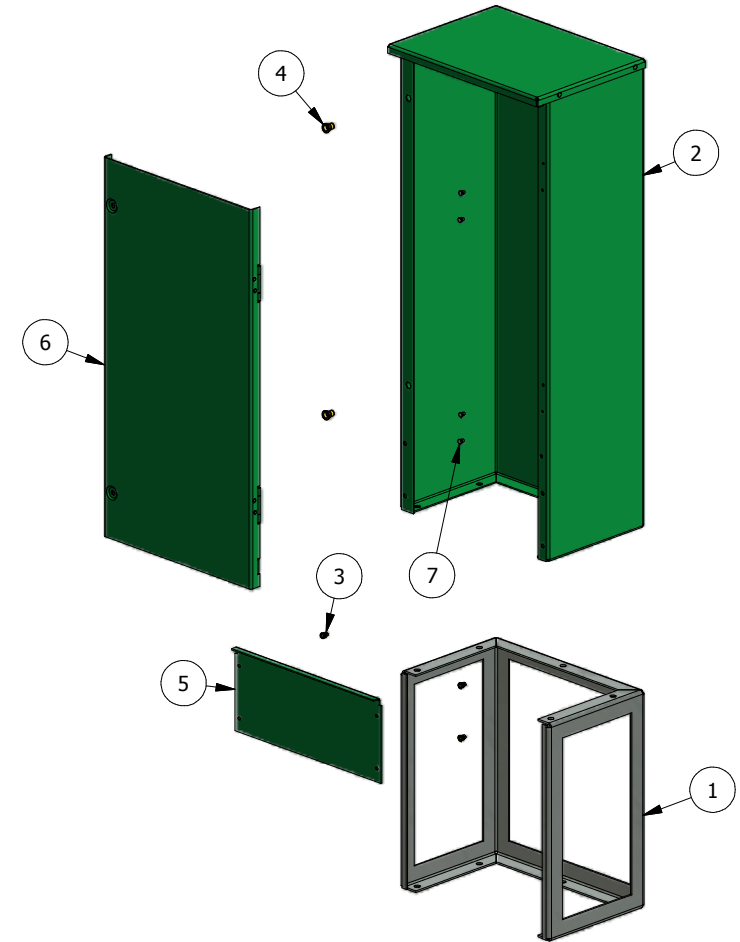

REVISION HISTORY

REV	DESCRIPTION	DATE	APPROVED	ECN #
L	body & door sub assemblies blank sizes revised	29/08/2014	JW	1472
M	door sub assembly updated	11/03/2015	JW	1542

	TOLERANCES: LINEAR: ±0.5 ANGULAR: ±0.5°	DRAWN: Chris Woods	DATE: 7/06/2011	CUSTOMER: RDL Limited	TITLE: AL365x900x260 ~ Final Assembly	DRAWING NO. - REV. 152-04-1007 (m)	
		CHECKED:	DATE:			Customer reference ~	
UNLESS OTHERWISE SPECIFIED: DIMENSIONS ARE IN MILLIMETERS				CAD GENERATED DRAWING DO NOT MANUALLY UPDATE DO NOT SCALE DRAWING	WEIGHT: 10.29 kg	MATERIAL: as parts	FINISH: as per specifications
SHEET OF SHEET: 1 / 1							